

POLTRONA TIPO
CHAIR TYPE
FAUTEUIL TYPE
SILLÓN MODELO

Linda3 e Linda3 ORL

ISTRUZIONI PER L'USO
OPERATING INSTRUCTIONS
MODE D'EMPLOI
MANUAL DE INSTRUCCIONES



DESIGN & MANUFACTURE

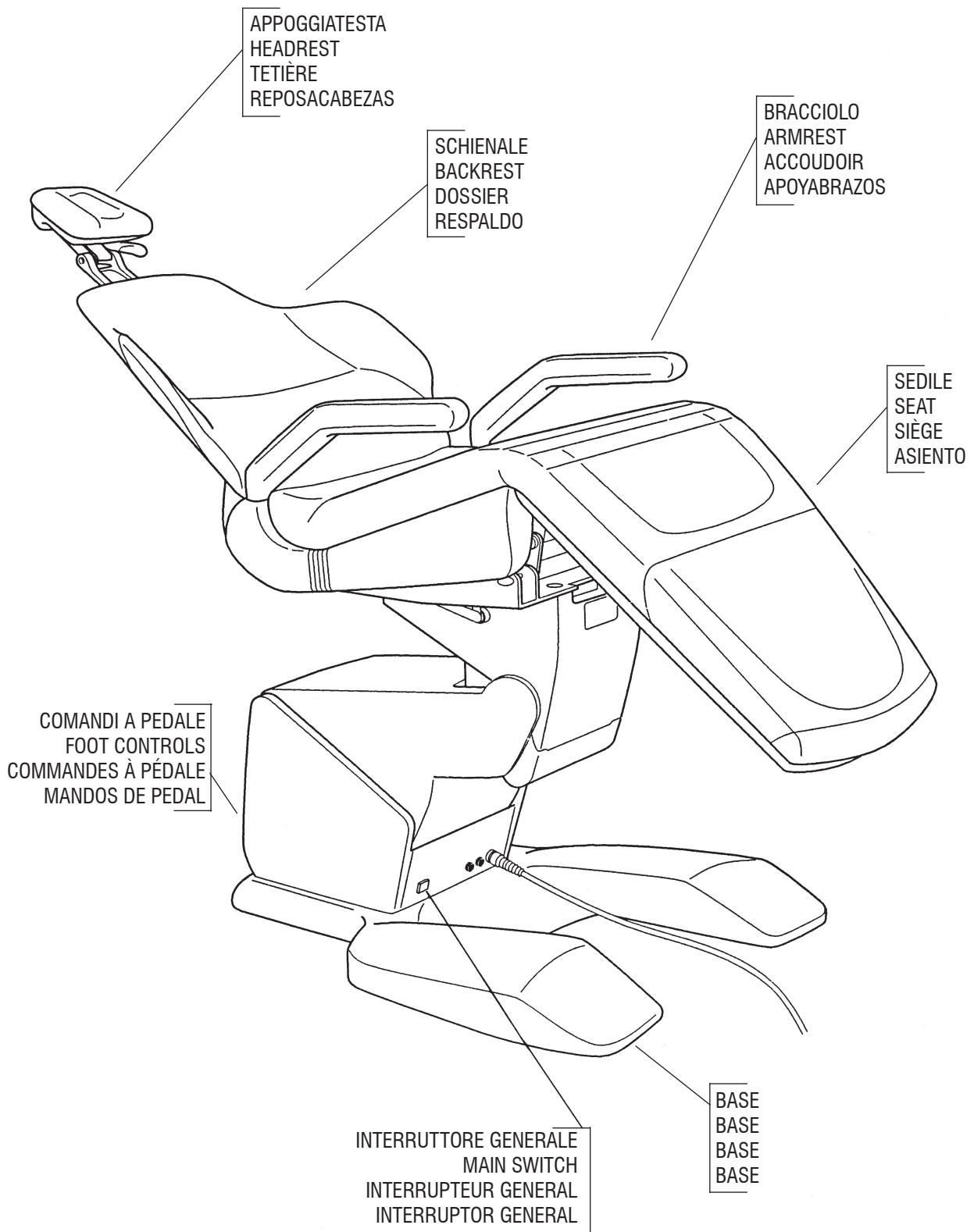

INDICE GENERALE MAIN INDEX INDEX GÉNÉRAL ÍNDICE GENERAL

ITALIANO pag. 4

ENGLISH pag. 21

FRANCAIS pag. 38

ESPAÑOL pag. 55



Poltrona testata dalla TÜV PRODUCT SERVICE
in base alle norme ISO 6875,
IEC 601-1, IEC 601-1-2.

The chair has been tested by TÜV PRODUCT
SERVICE according to ISO 6875,
IEC 601-1, IEC 601-1-2 International Standards.

Le fauteuil est testé par TÜV PRODUCT
SERVICE selon les
normes ISO 6875, IEC 601-1 et IEC 601-1-2.

Sillón sometido a ensayo por la TÜV PRODUCT
SERVICE según las normas ISO 6875, IEC 601-1
e IEC 601-1-2.



Poltrona conforme alla direttiva:
93/42/CEE concernente i dispositivi medici.

The chair complies with:
Medical Device Directive 93/42/EEC.

Fauteuil conforme aux directives:
93/42/CEE relative aux appareils médicaux.

Sillón conforme a las directivas:
93/42/CEE concerniente a los equipos médicos.

INDEX

1.0	Introduction	pag. 23
1.1	General features	pag. 23
1.2	Warranty	pag. 24
1.3	Identification	pag. 24
1.4	Technical data	pag. 25
2.0	Dental chair use	pag. 26
2.1	Controls	pag. 26
2.2	Operating instructions	pag. 27
2.3	Programming	pag. 28
3.0	Servicing	pag. 29
3.1	Cleaning	pag. 29
3.2	Troubleshooting	pag. 30
3.3	Main fuses replacement	pag. 32
3.4	Upholstery replacement	pag. 32
4.0	Accessories	pag. 33
4.1	Headrest	pag. 33
4.2	Armrests	pag. 35
4.3	Programs	pag. 35
4.4	Short seat upholstery	pag. 35
4.5	Rotation	pag. 35
5.0	Unpacking	pag. 36
5.1	Handling	pag. 36
6.0	Installation	pag. 37

GENERAL WARNING

The dental patient chair type Linda3 and the medical patient chair Linda3 ORL do not cause electromagnetic or other influences at other equipments. They are not susceptible of such influences by other equipments, as they complies with Electro-Magnetic Compatibility Directive 89/336/EEC, emended by 92/31/EEC and 93/68/EEC directives, and they satisfy the requirements of the EN 60601-1-2:1993 harmonized standard.

TECNODENT S.r.l. will make available on request circuit diagrams, components part list, descriptions, calibration instructions or other information which will assist the user's technical personnel to carry out reparation of those parts of the chair which are designed by the manufacturer as repairable.

WARNING



The manufacturer will accept responsibility for the security, reliability and performance of the equipment on the following conditions:

- **Installation and any repairs or modifications are carried out by authorised personnel only.**
- **The electrical wiring of the premises complies with all regulations currently in force at the time of installation.**
- **The equipment is used in accordance with the operating instructions.**

NOTE



Please note that in accordance with Art. 14 of EEC Directive 85/374 "Liability for damages arising from defective products" implemented in Italy by Decreto del Presidente della Repubblica 24 maggio 1988, n. 224; "Right to compensation ceases ten years after the day the manufacturer or the importer within the EU Nations first marketed the product, which is object of the claim".

OBJECT OF THIS MANUAL

This manual relates to the dental patient chair model Linda3 and the medical patient chair Linda3 ORL and includes information about their operation, performance, servicing, troubleshooting and corresponding solutions is addressed to the end-user, i.e. the professional who uses the apparatus in order to perform his/her own job.

DEFINITIONS

The following graphics and language definitions have been used in this manual:

NOTE



It contains important information, which has to be underlined in relation to the text.

CAUTION



This message can appear before some procedures description. Its non-compliance may cause damage to the apparatus.

WARNING



This message can appear before some procedures description. Its non-compliance may cause damage to the apparatus and to the operator.

DOUBLE FUNCTION CONTROL(S): footcontrol switch which activates multifarious chair functions, depending on how it is touched. (i.e.: pushing and holding -> manual chair movement. Tapping -> automatic movement of a preprogrammed working position)

SYNCHRONIZED MOVEMENT: simultaneous and interdependent variation of the position of two chair portions. It may occur both during a manual or an automatic movement. (i.e.: chair lifting combined with simultaneous backrest tilting).

COMPENSATED MOVEMENT: position variation of two chair parts acted by a motion system which takes into consideration ergonomical needs.

PCB: Printed circuit board

CN: Connector

PWR: Power

LED: Light bulb which normally advises the status (switched on or off) of an electric component or a PCB

TRANSPORT AND STORAGE

The chair is capable, while packed for transport or storage, of being exposed for a period not exceeding 10 weeks to environmental conditions not outside the following ranges:

- an ambient temperature range of -5 °C to +40 °C;
- a relative humidity range of 10% to 100%, including condensation;
- an atmospheric pressure range of 500 hPa to 1060 hPa (of 500 mbar to 1060 mbar).

ENVIRONMENTAL SAFEGUARD

PACKING DISPOSAL

The following materials used for packing, respect the environment and are 100% recyclable:

- wooden pallet with fumigation treatment,
- cardboard,
- polythene with air bubbles.

Collection and recycling of the packing materials, increase the saving of raw materials and decrease the amount of waste materials. Please give the packing to an authorized rubbish dump that collects this kind of materials.

CHAIR DISPOSAL

- When the chair reaches the end of its working life, it is necessary to definitely put it out of service, by disconnecting the plug from the socket and cutting the power supply cable.
- The chair disposal it is not related to any kind of effect on the human health.
- For a proper environmental safeguard, please give the out of service chair to an authorized waste collector for the materials that are part of the chair.



This symbol, placed in the identification label, indicates that the equipment's collection and disposal, must be performed separately from other kind of wastes.

1.0 INTRODUCTION

Linda3

This chapter offers a full view of the main features of the Linda3 dental patient chairs. The range of the main chair components and moreover corresponding accessories are shown.

WARNING



The apparatus is built for dental use only. No other use is permitted. It is furthermore not permitted any modification of the apparatus or of its parts without previous written authorization of the manufacturer.

1.1 GENERAL FEATURES

A dental patient chair type Linda3 with programmable working positions and/or without programmable working positions offers the following performances:

- Complete electromechanical raising, lowering and tilting of the backrest movements.
- Backrest tilting movement synchronized with the footrest extension to Trendelenburg position.
- Anatomical backrest with wings to support the patient's arms.
- Perfectly symmetrical chair, usable on both sides by a right-handed as well as a left-handed professional.
- Double foot controls.
- Security STOP on base, legrest and backrest.
- Program for the automatic return to "zero" position.
- Program for the automatic rinse position.
- Low voltage controls: 5 V.

In addition the chair can be equipped with different accessories, which consider the working needs of the professional as well as the comfort needs of the patient to be treated. In detail the following items can be installed onto the chair:

- Headrest type UNI TAPPEZZATO
- Headrest type ELLE MOBILE
- Headrest type ELLE FISSO
- Magnetic pillow C95
- Magnetic pillow C2002
- Right and/or left armrest(s)
- Rotating device around the vertical axe (ROTATION)
- Device for programming 3 different working positions (WITH PROGRAMS)
- Short seat upholstery

The function and the performance of these accessories are described in more detail in chapter 4.0.

Linda3 ORL

This chapter offers a full view of the main features of the Linda3 ORL medical patient chairs. The range of the main chair components and moreover corresponding accessories are shown.

WARNING



The apparatus is built for medical use only. No other use is permitted. It is furthermore not permitted any modification of the apparatus or of its parts without previous written authorization of the manufacturer.

1.1 GENERAL FEATURES

A medical patient chair type Linda3 ORL with programmable working positions offers the following performances:

- Complete electromechanical raising, lowering and tilting of the backrest movements.
- Backrest tilting movement synchronized with the footrest extension to Trendelenburg position.
- Anatomical backrest with wings to support the patient's arms, which soes 4° over the vertical position.
- Perfectly symmetrical chair, usable on both sides by a right-handed as well as a left-handed professional.
- Left and right armrests.
- Remote control.
- Security STOP on base, legrest and backrest.
- Rotation.
- Program for the automatic return to "zero" position.
- Program for the automatic rinse position.
- Low voltage controls: 5 V.

In addition the chair can be equipped with different accessories, which consider the working needs of the professional as well as the comfort needs of the patient to be treated. In detail the following items can be installed onto the chair:

- Headrest type UNI TAPPEZZATO
- Headrest type ELLE MOBILE
- Headrest type ELLE FISSO
- Magnetic pillow C95
- Magnetic pillow C2002
- Movable foot control

The function and the performance of these accessories are described in more detail in chapter 4.0.

1.2 WARRANTY

The apparatus is accompanied by the Warranty Certificate. If there is no such certificate, it must immediately be requested from the dealer, completely filled in and sent back to the manufacturer (TECNODENT S.r.l.) within 8 days from the date of delivery of the apparatus.

If this procedure is not observed, the warranty conditions are not valid and the servicing technicians will be compelled to entirely charge all technical interventions possibly needed.

1.3 IDENTIFICATION

The chair identification label, where you can find the chair model, the serial number and other information, is placed on the front of the chair under the seat. Fig. 1 shows the label position and a facsimile.

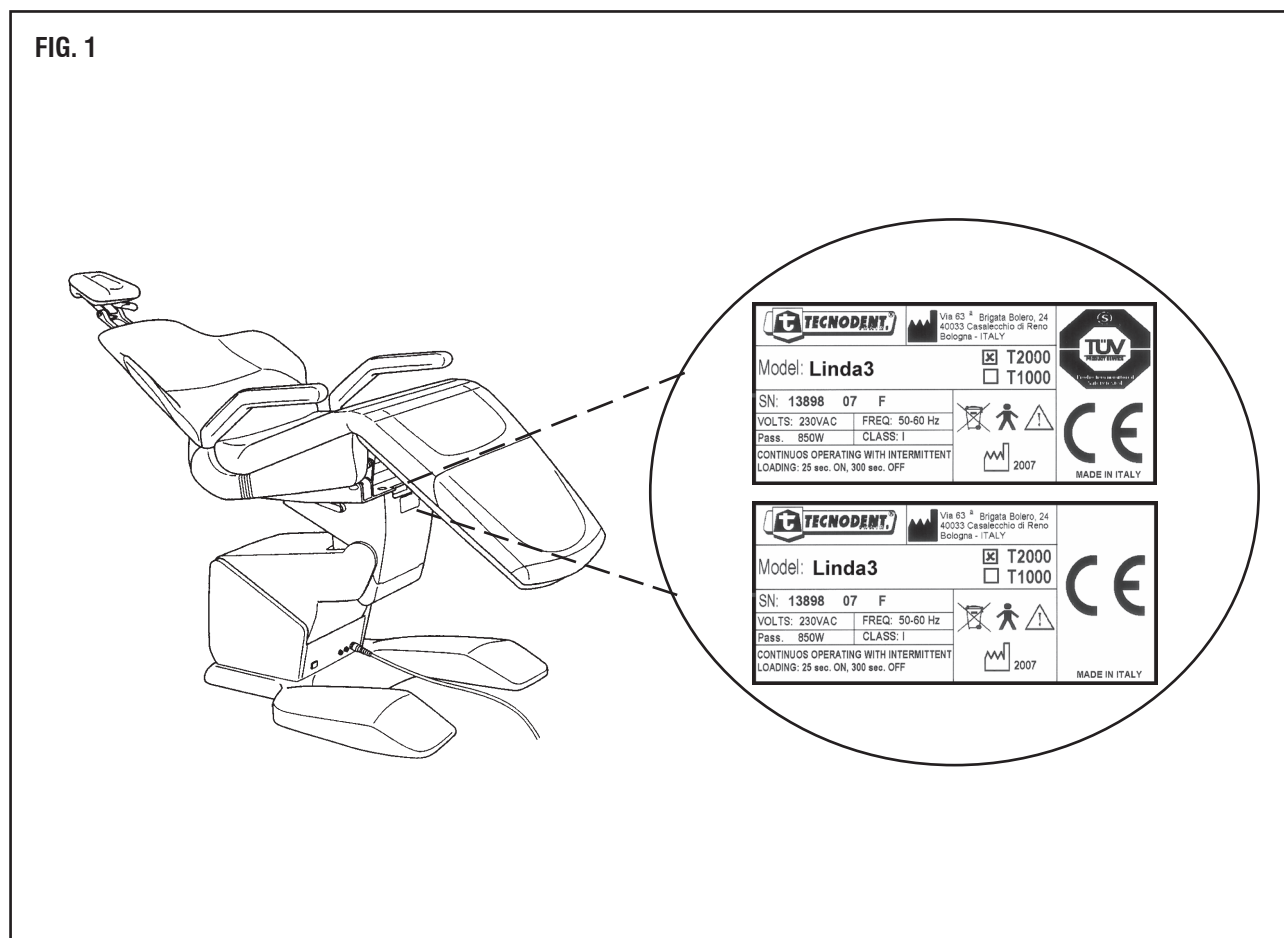

1.4 TECHNICAL DATA

The dental chairs model Linda3 and the medical chair model Linda3 ORL are in conformity with:

- Electro - Magnetic Compatibility Directive 89/336/EEC emended by 92/31/EEC and 93/68/EEC directives
- Medical Device Directive 93/42/EEC

Particularly the chairs comply with the requirements of the following standards:

- IEC 601-1-2:1993 = EN 60601-1-2:1993 = CEI EN 60601-1-2:1993
- ISO 6875:1995 = EN ISO 6875 : 1996
- IEC 601-1:1988 = EN 60601-1:1990 = CEI 62-5:1991

Chair sample of Linda3 has been tested by TÜV Product Service and it has got the GS mark.

According to the a/m standards the chairs model Linda3 and Linda3 ORL are medical devices classified as shown on table I.

Classification	I
Type	B
Operation mode	100/110 V Intermittent loading 20s ON - 200s OFF 230 V Intermittent loading 25s ON - 300s OFF

For chairs type Linda3 in both versions, with and without programs, and Linda3 ORL please refer to the technical data of table II and III. Measurements are shown more in detail in figure 2 and 3.

Connection to the supply	VAC	230±10%	100/110±10%
Supply frequency	Hz	50-60	50-60
Input	W	850	700
Supply input	A	4,0	7,5/6,9
Main fuses		2 x T 6.3 A 250 V	2 x F10 A 250 V
Controls voltage	VCC	5	5
External controls device provided		YES	YES

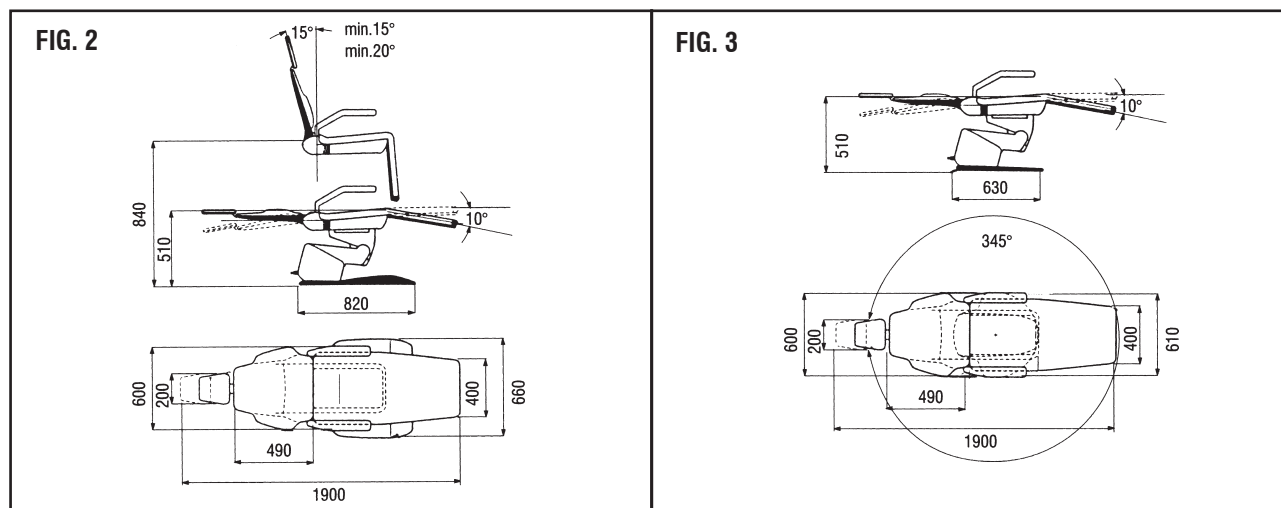

		Without rotation	With rotation
Max. height	mm	840	
Min. height	mm	510	
Width	mm	660	
Rotating angle	deg	---	345°
Length (With completely elongated headrest)	mm	1900	
Gross weight	Kg	145	
Net weight	Kg	115	
Packing dimensions	mm	1430x700x970 (h)	
Maximum lifting capability (patient+unit)	Kg	135+75	
Minimum space required for installation	m	3x2	3x3

2.0 DENTAL CHAIR USE

The advanced technology applied to the production of this apparatus has allowed the design of a dental patient chair with multiple functions and performances, all of them easily usable: all regulations and functions of the chair are coordinated, processed and stored in a "data bank", by a microprocessor inside the chair. The dental patient chair Linda3 is designed to be easily controlled by foot controls, allowing the professional's hands to be completely free to operate in the patient's mouth.

WARNING:



Before using the information contained in this section, make sure that the chair is correctly installed, by the service technician.

2.1 CONTROLS

Linda3 CHAIR WITHOUT PROGRAMS (PCB T1000)

The controls are shown on figure 4.a:

- P Main switch (Power on/off).
- L Double footcontrol, placed on the base. It controls raising, lowering and backrest tilt manual movements of the chair and the automatic return to "zero" position.
- S Controls the automatic movement of rinse position, in order to allow the patient's mouth wash and the return to the last working position.

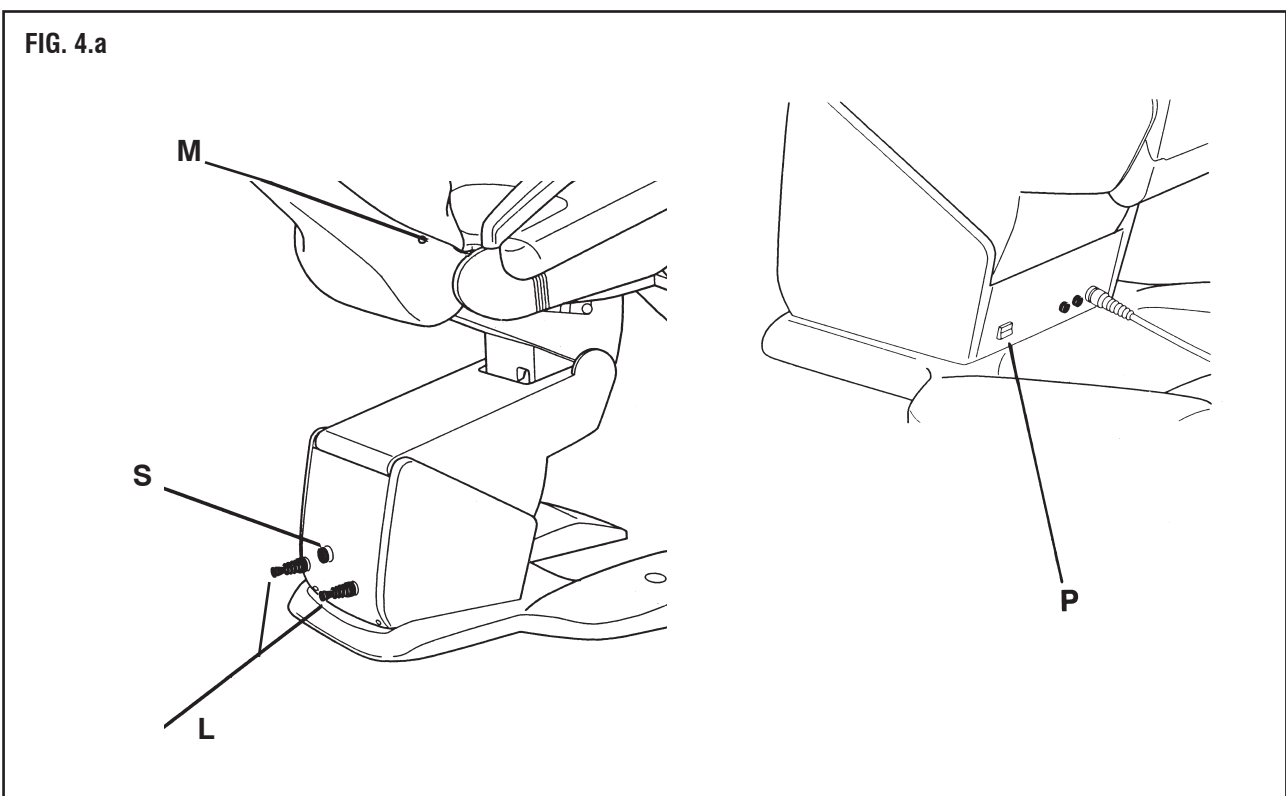

Linda3 CHAIR WITH PROGRAMS (PCB T2000)

The controls are shown on figure 4.a:

- P Main switch (Power on/off).
- L Double function footcontrols, placed on the base. They control the raising, lowering and backrest tilt manual movements of the chair, as well as the 3 programmable working positions and the automatic reset to "zero" position.
- S Controls the automatic movement of rinse position in order to allow the patient's mouth wash and the return to the last working position.
- M Stores the programmed working positions.

Linda3 ORL CHAIR

The controls are shown on figure 4.b:

- P Main switch (Power on/off).
- T Remote control.
- M Stores the programmed working position (see fig. 4.a).

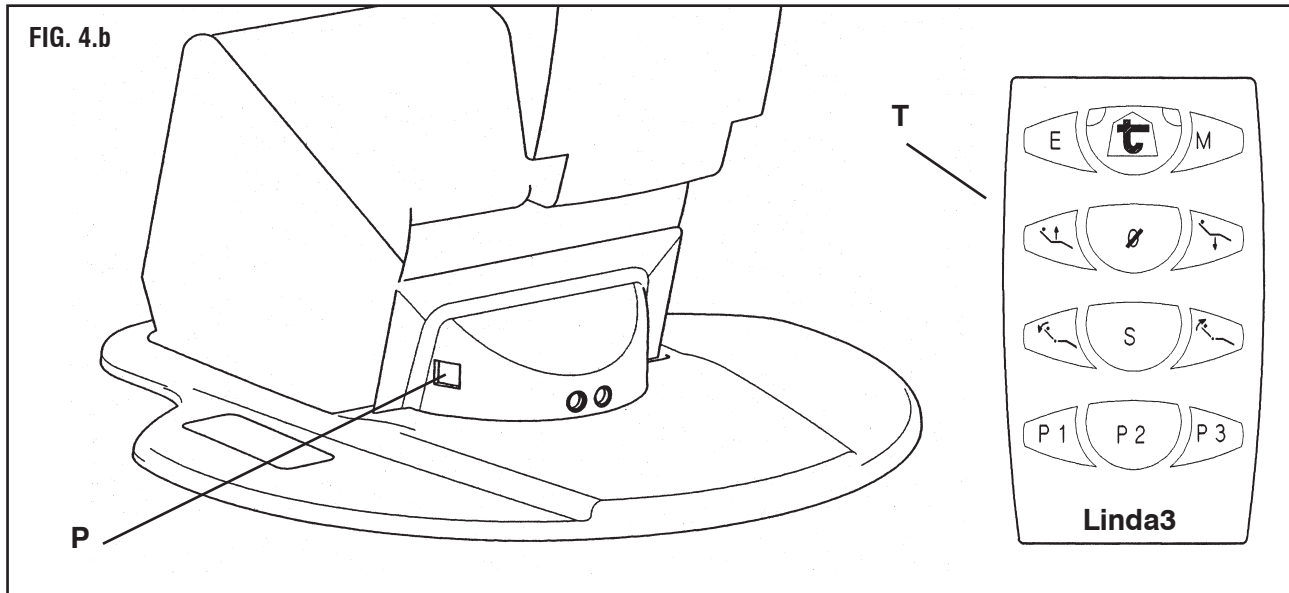

2.2 OPERATING INSTRUCTIONS

Linda3 CHAIR WITHOUT PROGRAMS

Insert the plug into the socket and switch on the main switch P. Now the chair is ready to work.

OPERATING INSTRUCTIONS FOR THE JOYSTICK L

- while keeping the joystick downward the chair lowers
- while keeping the joystick upward the chair lifts
- while keeping the joystick towards the outside the chair backrest moves to the vertical position
- while keeping the joystick towards the inside the chair backrest moves to the supine position
- while tapping the joystick downward the chair moves automatically to the reset "zero" position

OPERATING INSTRUCTIONS FOR THE PUSHBUTTON "S"

- while pushing "S" the rinse position function is activated; the chair backrest moves up to vertical position to allow the mouthwash
- while pushing "S" again the chair backrest moves back to its last position

NOTE



Any switch, if pushed during an automatic movement, works like a security STOP.

NOTE:



Any switch, if pushed during the automatic reset to "zero" position movement, works like a security STOP.

Linda3 CHAIR WITH PROGRAMS

Insert the plug into the socket and switch on the main switch P. Now the chair is ready to be used: this condition is confirmed by the double sound signal (BEEP-BEEP) which indicates the good order of the chair.

OPERATING INSTRUCTIONS FOR THE JOYSTICK L

- while keeping pressed the joystick downward the chair lowers
- while keeping pressed the joystick upward the chair lifts
- while keeping pressed the joystick towards the outside the chair backrest moves to the vertical position
- while keeping pressed the joystick towards the inside the chair backrest moves to the supine position
- while tapping the joystick upward, towards the outside or towards the inside, the chair moves automatically to the programmed working positions
- while tapping the joystick downward the chair moves automatically to the reset "zero" position

OPERATING INSTRUCTIONS FOR THE PUSHBUTTON "S"

- while pushing "S" the rinse position function is activated; the chair backrest moves up to vertical position to allow the mouthwash
- while pushing "S" again the chair backrest moves back to its last position

NOTE



Any switch, if pushed during an automatic movement, works like a security STOP.

NOTE







Any switch, if pushed during the automatic reset to "zero" position movement, works like a security STOP.

Linda 3 ORL CHAIR

Insert the plug into the socket and switch on the main switch P. Now the chair is ready to work: this condition is confirmed by the double signal (BEEP - BEEP) which indicated the good order the chair.

OPERATING INSTRUCTIONS FOR THE REMOTE CONTROL T

- while keeping pressed  the chair lowers
- while keeping pressed  the chair lifts
- while keeping pressed  the chair backrest moves to the vertical position
- while keeping pressed  the chair backrest moves to the supine position
- pressing "P1", "P2", "P3" the chair moves automatically to the programmed working position
- pressing "Ø" the chair moves automatically to the reset "zero" position

BATTERY REPLACEMENT

- I Remove the screw placed on the rear of the remote control.
- II Remove the back cover of the remote control.
- III Replace the battery with a new one having the same characteristics (2 x AAAA 1,5V).
- IV For assembling the back cover once again repeat the same actions in reverse.

CAUTION



Remove the battery if the remote control is not used for some time.

2.3 PROGRAMMING

This operation is only available on chairs equipped with this feature.

PROGRAMMING PROCEDURE

- I Drive the chair to the automatic reset to "zero" position, by tapping the joystick downward, or pushing the "Ø" button on the remote control.
- II Drive the chair manually to the working position You desire to program, by joystick L or by the remote control (see paragraph 2.2).
- III While keeping "M" - the programming pushbutton located on the right-hand side of the backrest - tap the joystick upward (position "1"), towards the outside (position "2") or towards the inside (position "3") or the buttons "P1", "P2" and "P3" on the remote control - according to the program number You have selected . A sound-signal (BEEP) confirms that the working position has been memorized. Any time You tap the joystick upward, towards the outside or towards the inside again or the buttons "P1", "P2" and "P3" on the remote control, the chair moves automatically to the programmed working position You have selected.

NOTE

To avoid losing the programmed position, it is recommended to regularly set the chair to its "zero" position, using the function "0", at any patient change.

3.0 SERVICING

The Linda3 and Linda3 ORL chairs are made to require no servicing during their life. There are thus no specific readjustments of the apparatus to be carried out at any time. If the chair is not operated for some time, it is recommended to cover it, to switch the main switch off and to disconnect the plug from the socket.

WARNING

It is recommended that any technical adjustment as well as any repair of the apparatus not specifically listed in this chapter is carried out by qualified technicians.

3.1 CLEANING

For a better and longer life of the apparatus it is necessary to execute methodically and periodically an accurate general cleaning of the chair. It is recommended to proceed as follows:

UPHOLSTERIES

The fabric covering the chair upholstery has to be wiped by the liquid contained in the bottle kit accompanying the chair, using a soft cloth in order to avoid any surface chap and to guarantee a better elasticity and smoothness of the surface.

NOTE

As soon as the bottle liquid runs out, it is recommended to order some more from the closest sales and servicing center.

POLYURETHANE (PU) AND PAINTED PARTS

The polyurethane parts, as well as the metal parts (painted and not painted) have to be wiped with a cloth dipped in soap and water.

CAUTION

It is recommended to avoid the use of any detergent or strong abrasive agent for removing the "difficult stains".

3.2 TROUBLESHOOTING

The steps to detect a faulty condition on the Linda3 chairs are described in table-form. Each table reports the title of the troubleshooting procedure, and three columns in which it is possible to detect and solve the problem. Below is an example:

Procedure name		
Problem	Test procedure	Corrective action(s)
Dental patient chair problem description.	If the answer to the proposed question is "YES" look at the question written in the next box below; if the answer to the question is "NO" take all the corrective action(s) described in the right box before moving to the next question.	Action(s) to be carried out in order to fulfill the requirements of the question asked by the test procedure at the side. Only after all actions have been carried out with positive result it is possible to move to the next test procedure.

The table-form takes into consideration only electrical or electronic faulty conditions as mechanical faults are easily detectable by a simple visual inspection. In order to execute a visual inspection it is sufficient to remove the upholstery parts, as described in paragraph 3.4.

Mains control procedure		
No chair movement	Is the supply voltage correctly rated?	If not OHM-meter or a similar testing device is available, plug any other apparatus (i.e. a lamp) into the socket and verify the presence of the power supply.
	Is the power cord plugged in?	Plug the cord into the socket.
	Is the green light of the main switch on?	Turn the main switch on.
		After having unplugged the chair, check the main fuses. If necessary, replace them as described on the servicing manual. On the contrary call the servicing technicians.
	Does the PCB emit a double sound "BEEP" when the main switch is turned on? (Only for programmable Linda3 chairs).	The PCB has probably failed. Call the servicing technicians.
The problem is not located in the chair main supply group. Continue checking the chair movements one by one.		

Chair lifting movement control procedure		
The chair doesn't lift.	Is there too much weight on the chair?	Apply the chair movement testing procedure. See next page.
	Remove the excessive weight. Look at the chair operating instruction manual to determine the maximum chair lifting capability.	

Backrest raising movement control procedure		
The chair backrest doesn't tilt.	Is there an object that collides with the chair, activating the security device and stopping the backrest tilt movement?	Apply the chair movement testing procedure.
	Remove the obstacle.	

Backrest raising movement control procedure		
The chair backrest doesn't raise.	Was the chair movement testing procedure duly applied?	Apply the chair movement testing procedure.
	Call the servicing technicians	

Chair movement testing procedure		
The chair doesn't move at all, even if the main switch is switched on and the mains group is working correctly.	Do You hear a "CLICK" sound when You try to activate the foot controls?	If no "CLICK" sound is emitted probably the PCB has failed. Call the servicing technicians.
	Does the motor hum?	The motor may have over-heated and the thermal security switch may have turned on. Wait for about 15 minutes, allowing the motor to cool down and operate the motor again. If the chair doesn't move or the motor overheats immediately after, call the servicing technicians.
	It is impossible to determine the cause of the failure unless further and more complex testing is applied. Call the servicing technicians.	

Chair programming control procedure (only for programmable Linda3 chairs)		
The chair moves properly in all manual movements, but it is impossible to store working position programs.	Was the programming procedure, as explained in the instruction manual properly applied?	Apply the programming procedure written in the instruction operating manual.
	Does any "BEEP" sound - when the programming switch is pushed and simultaneously one of the program-button is tapped - in order to memorize one of the 3 working positions?	It is impossible to determine the cause of the failure unless further and more complex testing is applied. Call the servicing technicians.
	Probably the PCB has failed. Call the servicing technicians	

3.3 MAIN FUSES REPLACEMENT

As shown on figure 5 the Linda3 chair is protected against electrical power over-rating by two fuses placed on the front side of the chair, close to the base. In order to replace them, proceed as follows:

- I Switch off the main switch.
- II Disconnect the plug from the socket.
- III Unscrew the fuse holder cap by using a crosshead screw driver of medium size.
- IV In order to re-install the fuses repeat the same actions in reverse.

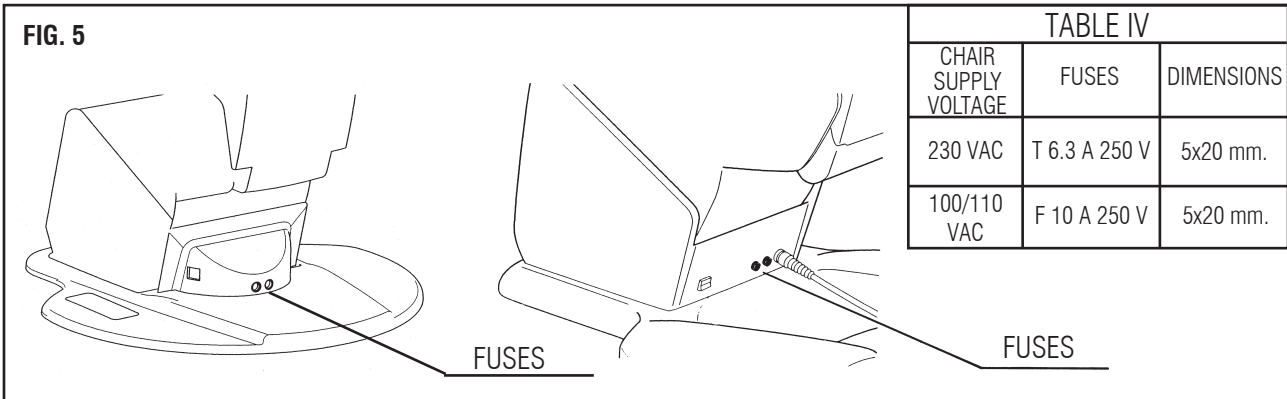

WARNING



Fuses must be replaced by other fuses having the same nominal features. Table IV reports such information.

3.4 UPHOLSTERY REPLACEMENT

In order to replace the chair upholstery proceed as follows and as shown on figure 6:

SEAT

- I Drive the chair to a semi-lying position.
- II Lift the upholstery by pulling slightly and separate it from its counterpart starting from the footrest, then the seat, and finally the last part, close to the backrest.
- III In order to reinstall the seat upholstery, repeat the same actions in reverse.

NOTE



If the seat upholstery of Your chair is of the shortened version, before proceeding as indicated at point II, unscrew the two screws to remove the last part of the footrest and unscrew the two screws that fix the legrest upholstery to the counter seat.

BACKREST

- I The backrest upholstery is mounted by pressure with six special plastic caps. In order to remove it from its counterpart it is enough to pull it away, applying a bit of strength.
- II In order to reinstall the seat upholstery, repeat the same actions in reserve.

HEADREST

- I To replace the headrest upholstery refer to paragraph 4.1.

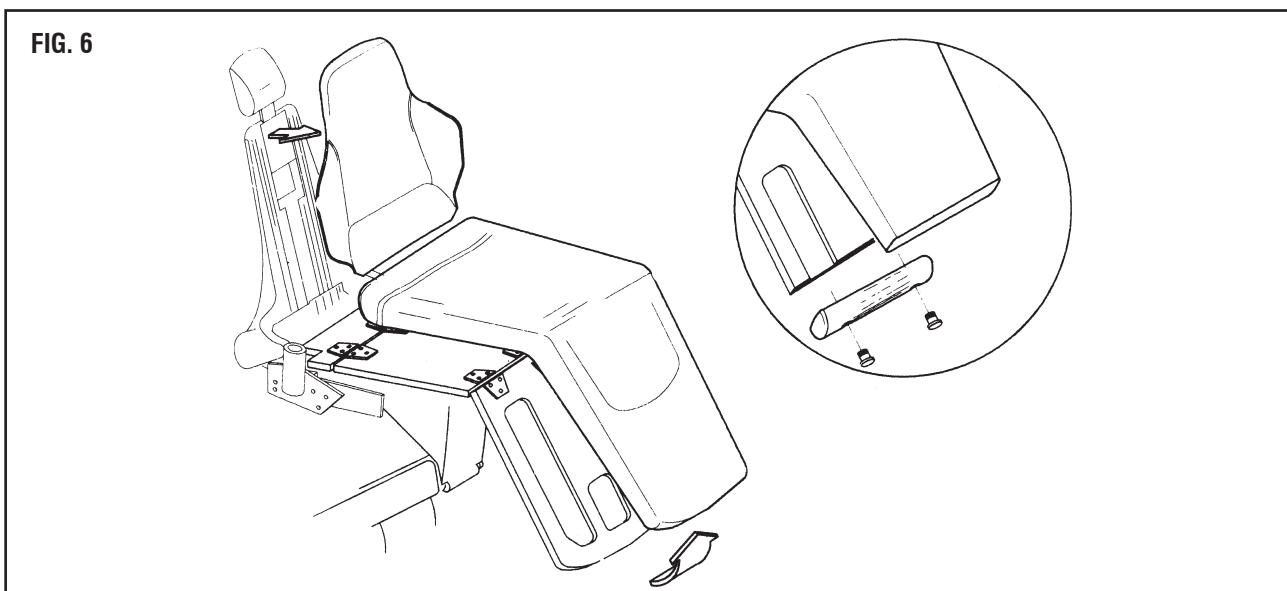

4.0 ACCESSORIES

4.1 HEADREST

Upon request the Linda3 chair can be equipped with different types of headrest.

HEADREST TYPE "UNI TAPPEZZATO"

This headrest allows the optimum positioning of the patient's head, according to the treatment to be applied, thanks to its double articulating mechanism. It is also easily adjusted in height (see fig. 7).

FUNCTION

- the adjustment of the double articulation can be made by means of the handle "R" that can be turned clockwise in order to unlock the mechanism. As soon as the optimum head position is reached, lock the mechanism turning the handle "R" anti-clockwise.
- pushing and holding the cam "H", located on the right hand side of the backrest the locking mechanism of the headrest sward is released and the headrest can be adjusted in height. As soon as the optimum head position is reached, by releasing the cam the headrest sward is locked in its new position.

SERVICING

- the headrest upholstery can be easily replaced by simply pulling it and separating it from its counterpart.

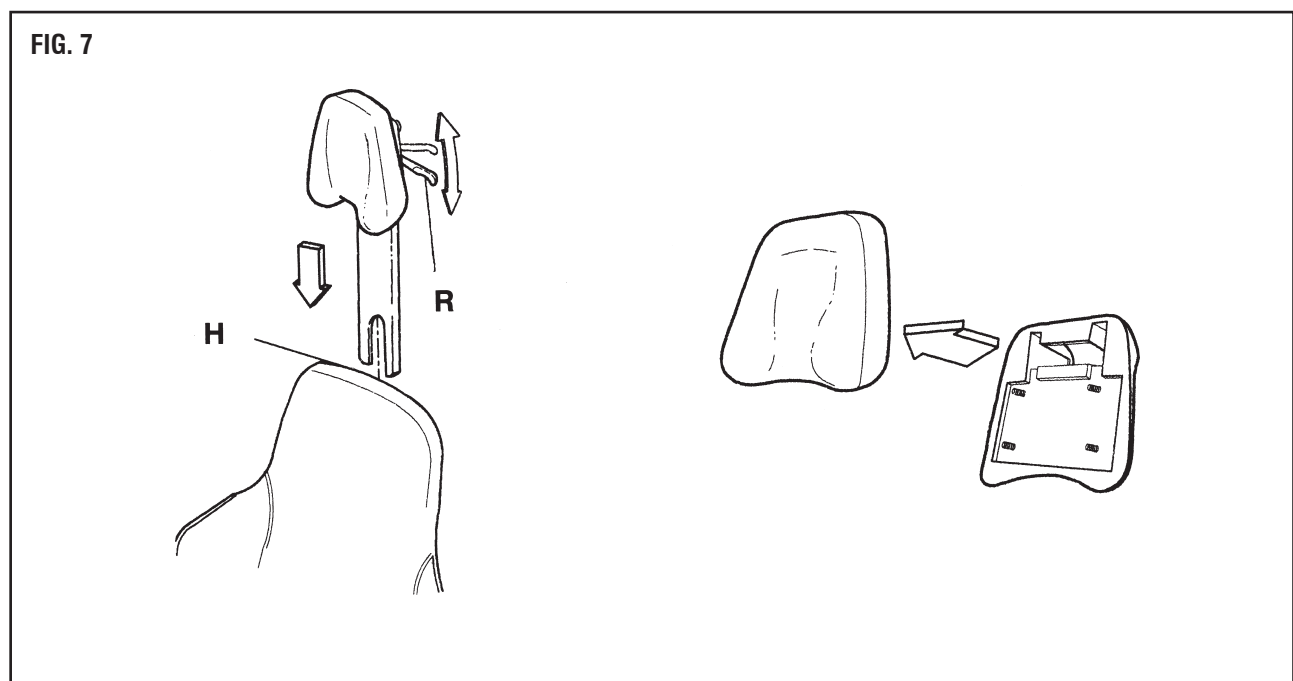

HEADREST TYPE "ELLE MOBILE"

This headrest allows the positioning of the patient's head by adjusting its elongation as well as its inclination angle as shown on figure 8.

FUNCTION

- the forward headrest adjustment occurs when it is pushed from the back towards the patient's head. The backward adjustment is made when the headrest is pulled from the upholstery side, while simultaneously pushing the release button "T".
- pushing and holding the cam "H", located on the right hand side of the backrest, releases the locking mechanism of the headrest blade and the headrest can then be adjusted in height. As soon as the optimum head position is reached, by releasing the cam, the headrest blade locks in its new position

SERVICING

- the headrest upholstery can easily be replaced by simply pulling and separating it from its counterpart.

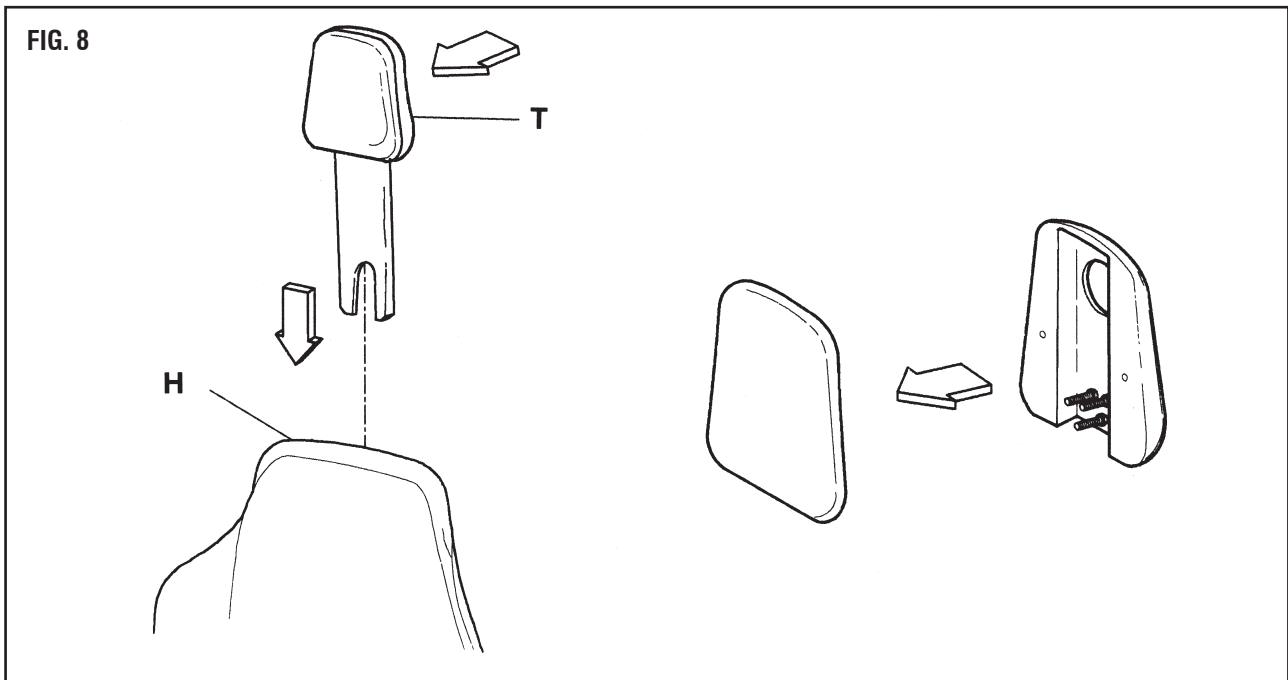

HEADREST TYPE "ELLE FISSO"

This headrest allows the elongation adjusting only as shown on figure 9.

FUNCTION

- pushing and holding the cam "H", located on the right hand side of the backrest, the locking mechanism of the headrest blade is released and the headrest can be adjusted in height. As soon as the optimum head position is reached, by releasing the cam the headrest blade locks in its new position.

SERVICING

- the headrest upholstery can be easily replaced by simply pulling and separating it from its counterpart.

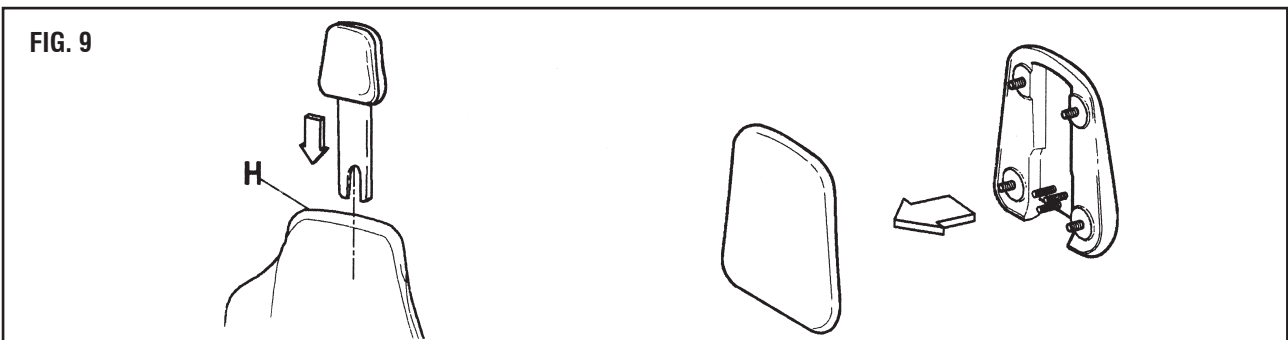

MAGNETIC PILLOW TYPE "C95" OR "C2002"

The magnetic pillow, as shown on figure 10, can be employed in specific treatments for holding the patient's head. It can be attached to the surface of the upholstery of the "ELLE MOBILE" or "ELLE FISSO" headrest, as well as to the chair backrest upper section, in the case where the patient's height is too short to reach the headrest (i.e.: a child).

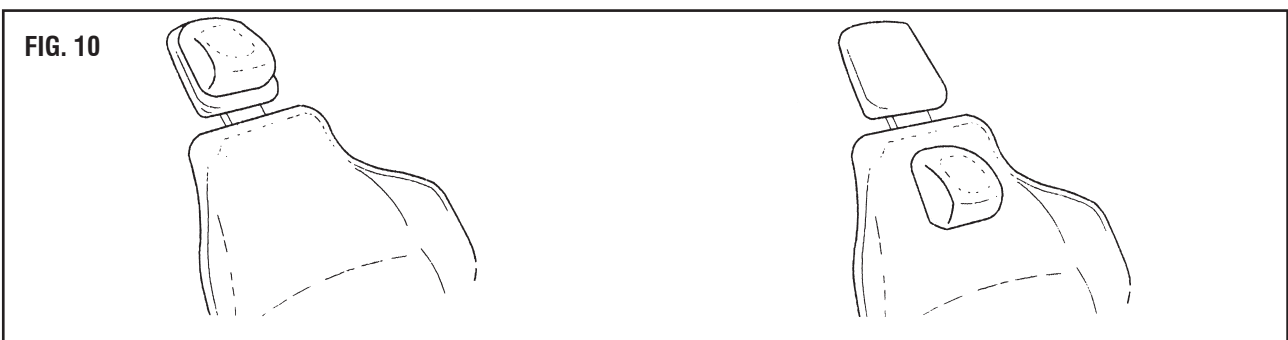

4.2 ARMRESTS

The chair can be equipped with armrests, both right and left (see fig. 11).

OPERATION

- In order to swivel the armrest it is necessary to pull it upwards (holding it from its bottom) until swiveling mechanism is unlocked and to swivel it outwards, until it reaches its stroke limit. In order to move the armrest back to its original position it is enough to turn it inwards, until it is automatically locked.

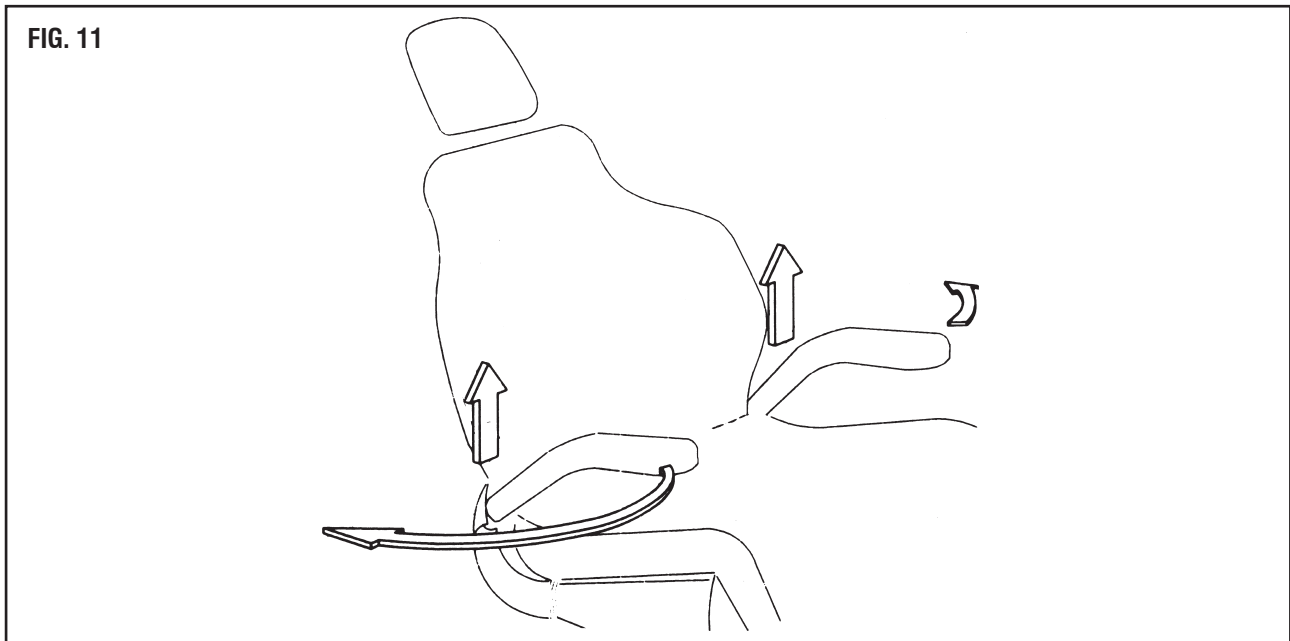

4.3 PROGRAMS

Upon request, at the moment of the order, the chair can be equipped with a programming device which allows the operator to program 3 different working positions, which can be activated at any time.

OPERATION

See paragraph 2.2.

NOTE



The Linda3 ORL chair is always equipped with programs.

4.4 SHORT SEAT UPHOLSTERY

Upon request the chair can be equipped with a short seat upholstery. This feature is particularly useful when the professional very often treats short height patients (i.e. children). The short seat upholstery is particularly for installation in small rooms, such as mobile treatment centres. (i.e. ambulance or similar).

NOTE



The Linda3 ORL chair is always equipped with short seat upholstery.

4.5 ROTATION

Upon request the Linda3 chair can be equipped with a rotating device which allows the chair to swivel around its vertical axe.

In order to unlock the rotating mechanism, push the footcontrol seated on the base: now it is possible to swivel the chair manually to the desired position.

In order to lock the mechanism, push the footcontrol again.

WARNING



After every re-adjustment of the chair position, always lock the rotating device.

NOTE



The Linda3 ORL chair is always equipped with rotation.

5.0 UNPACKING

To remove the carton-box firstly cut the straps, then unscrew the screws at the bottom of the carton. As soon as the carton box is removed, You will find the following objects:

- I A dental patient chair type Linda3 or medical patient chair type Linda3 ORL.
- II An operating instruction manual.
- III A warranty certificate.
- IV A bottle kit for wiping the chair upholstery.
- V Two PU caps for closing the fixing holes of the chair base (for Linda3 only).
- VI Two handles.

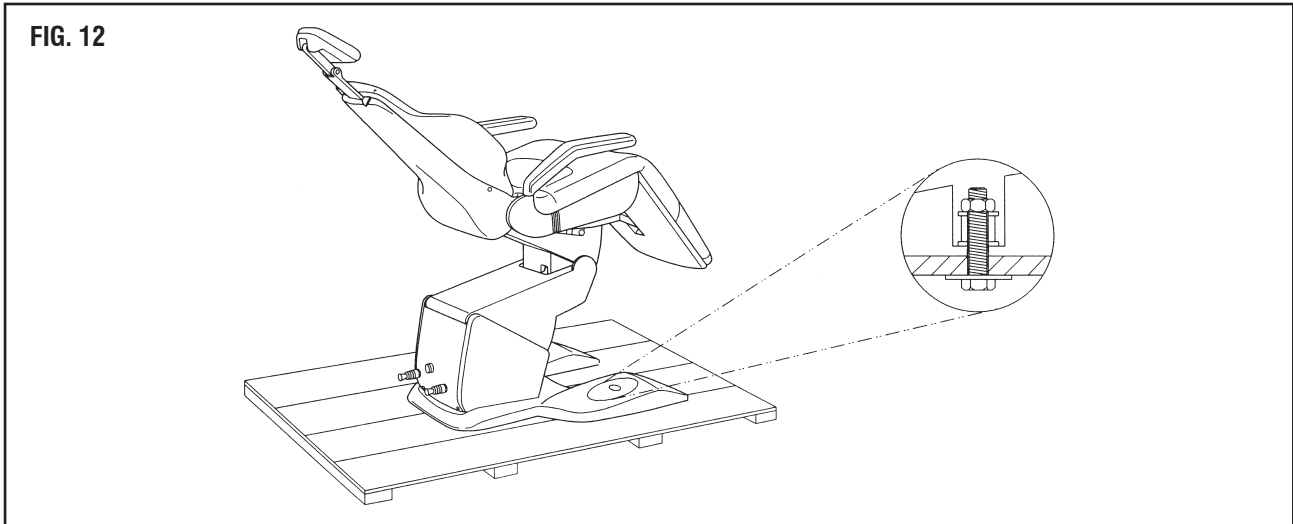

5.1 HANDLING

To remove the chair from the wooden pallet, first take the two caps off, then unscrew the two screws which fix the chair base to the pallet (see fig. 12).

To move the chair from the wooden pallet employ two people.

To move the chair, hold it by the two handles.

After positioning the chair, remove the handles.

In order to uninstall these two handles (see fig. 13) proceed as follow:

- I Unscrew the allen screws 1 and 2 placed under the seat, right side.
- II Remove the right handle.
- III Unscrew the allen screws 3 and 4 placed under the seat, left side.
- IV Remove the left handle.

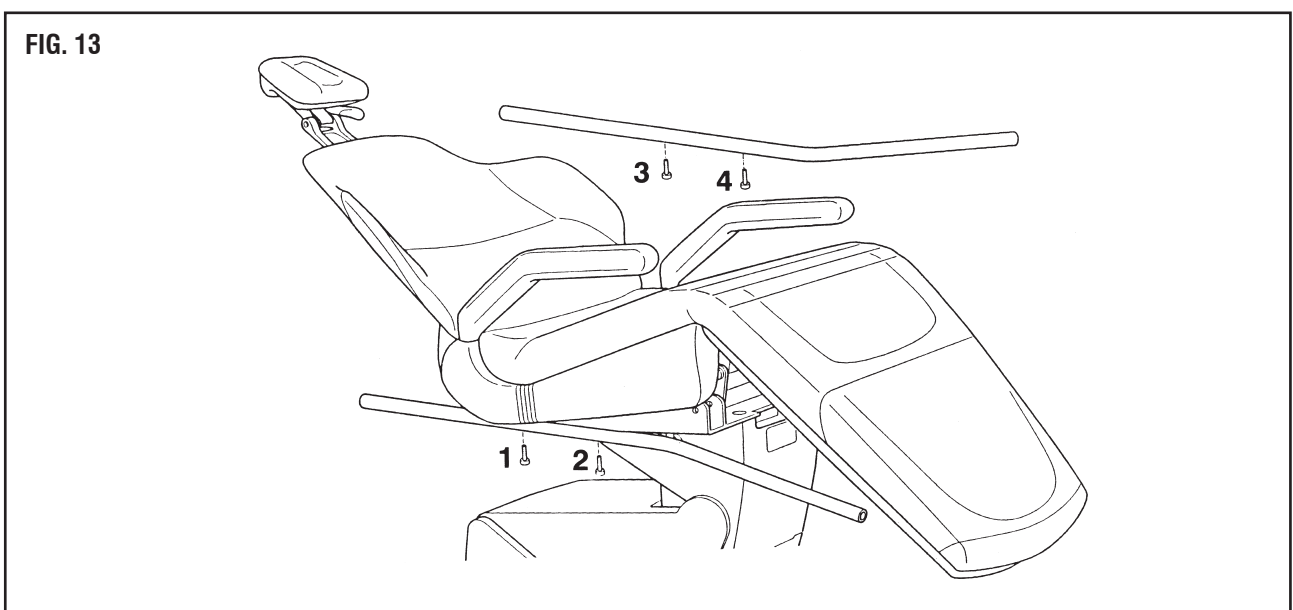

6.0 INSTALLATION

After having placed the chair into the desired position, having - if necessary - fixed it to the floor by the two holes on the base (figure 14), proceed as follows:

- I Be sure that the dental cabinet has got a good earth.
- II Be sure that the main supply of the electrical wiring of the cabinet corresponds to the one of the identification label.
- III Check that the fuses, located at the front side of the chair near to the base, are correctly fixed, because during transport they could have become loose.
- IV Insert the plug into the socket.
- V Activate the chair switching the main switch on. Now the chair is ready to work. In case of non operation of the chair, refer to paragraph 3.2 about trouble-shooting.
- VI If a unit is required, then drive the chair to the optimum height and fix the unit bracket as per unit manufacturer's instructions.

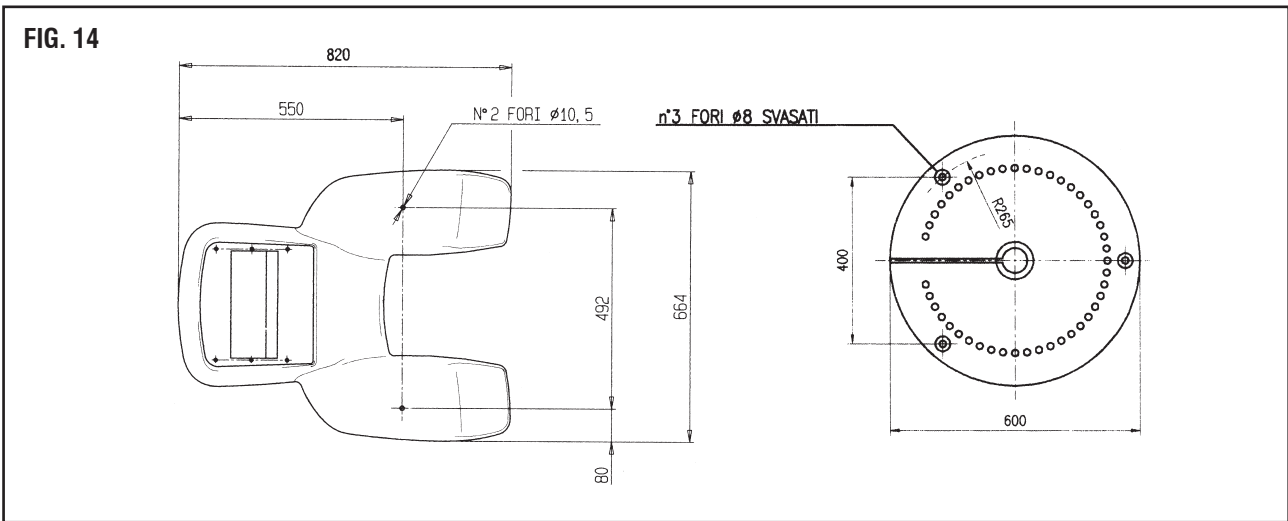
**WARNING**

TECNODENT S.r.l. declines all and any responsibility for damage caused by the non-compliance with the above instructions.